



# Quick Start Guide



## Cisco 220 Series Smart Plus Switches

### Package Contents

- Cisco 220 Series Smart Plus Switch
- Power Cord
- Rack-Mount Kit and Rubber Feet
- Console Cable
- This Quick Start Guide
- Product CD
- Technical Support Contacts

# Welcome

Thank you for choosing the Cisco 220 Series Smart Plus Switch, a Cisco network communications device. This device is designed to be operational right out-of-the-box as a standard bridge. In the default configuration, it will forward packets between connecting devices after power up.

This guide familiarizes you with the layout of the switch and describes how to deploy the switch in your network. For additional information, see [www.cisco.com/go/220switches](http://www.cisco.com/go/220switches).

## 1 Before You Begin

Before you begin the installation, make sure that you have the following:

- RJ-45 Ethernet cables (Category 5E or higher) for connecting network devices.
- Console cable for using the console port to manage your switch.
- Tools for installing the hardware. The rack-mount kit packed with the switch contains four rubber feet for desktop placement, and two brackets and twelve screws for rack-mounting.
- PC with Internet Explorer (version 8.0 and higher), Firefox (version 20.0 or higher), Chrome (version 23.0 or higher), or Safari (version 5.7 or higher) for using the web-based interface or the console port to manage your switch.

## 2 Cisco 220 Switch Features

This section describes the available product models and the exterior of the switch to help familiarize you with your switch.

### Product Models

Model	Description	Ports
SF220-24	24-Port 10/100 Smart Plus Switch	24 FE Copper + 2 GE Combo
SF220-24P	24-Port 10/100 PoE Smart Plus Switch	24 FE Copper + 2 GE Combo
SF220-48	48-Port 10/100 Smart Plus Switch	48 FE Copper + 2 GE Combo

Model	Description	Ports
SF220-48P	48-Port 10/100 PoE Smart Plus Switch	48 FE Copper + 2 GE Combo
SG220-26	26-Port Gigabit Smart Plus Switch	24 GE Copper + 2 GE Combo
SG220-26P	26-Port Gigabit PoE Smart Plus Switch	24 GE Copper + 2 GE Combo
SG220-50	50-Port Gigabit Smart Plus Switch	48 GE Copper + 2 GE Combo
SG220-50P	50-Port Gigabit PoE Smart Plus Switch	48 GE Copper + 2 GE Combo

## Front Panel

The ports, LEDs, and Reset button are located on the front panel of the switch.

### Left Side

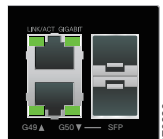
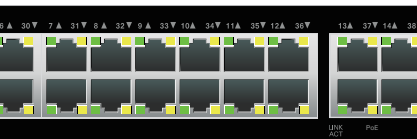
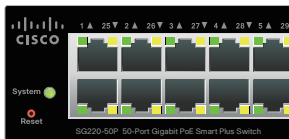
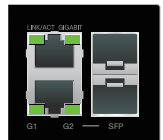
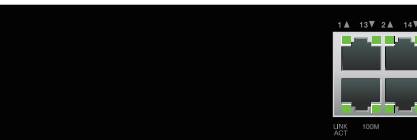

370926

**RJ-45 Ethernet Ports**—The RJ-45 Ethernet ports connect network devices, such as computers, printers, and access points, to the switch.

**SFP Ports**—The small form-factor pluggable (SFP) ports are connection points for modules so that the switch can link to other switches. These ports are also commonly referred to as mini Gigabit Interface Converter (miniGBIC) ports. The term SFP will be used in this guide.

- The SFP ports are compatible with Cisco modules MFEBX1, MFEFX1, MFELX1, MGBLH1, MGBLX1, MGBSX1, MGBSX1, MGBSX1, and MGBT1.
- The SFP port is shared with one other RJ-45 port, called a combo port. When the SFP port is active, the adjacent RJ-45 port is disabled.
- The LEDs of the corresponding RJ-45 ports flash green to respond to the SFP port traffic.

**Reset Button**—The Reset button is used to reboot or reset the switch with a pin or paper clip. See [Returning the Cisco 220 Switch to the Factory Default Settings](#) for more information.

**System LED**—(Green) Lights steady when the switch is powered on, and flashes green when booting, performing self-tests, and/or acquiring an IP address. If the LED flashes amber, the switch has detected a hardware failure, a firmware failure, and/or a configuration file error.

**Link/ACT LED**—(Green) Located on the left of the port. Lights steady when a link between the corresponding port and other device is detected. Flashes when the port is passing traffic.

**NOTE** The System and LINK/ACT LEDs are on each model of the switch. The LEDs that follow are only present on the switch models that have those capabilities.

**100M LED (if present)**—(Green) Located on the right of the port. Lights steady when other device is connected to the port, is powered on, and a 100 Mbps link is established between the devices. When the LED is off, the connection speed is under 100 Mbps or nothing is cabled to the port.

**GIGABIT LED (if present)**—(Green) Located on the right of the port. Lights steady when another device is connected to the port, is powered on, and a 1000 Mbps link is established between the devices. When the LED is off, the connection speed is under 1000 Mbps or nothing is cabled to the port.

**PoE LED (if present)**—(Amber) Located on the right of the port. Lights steady to indicate that power is being supplied to a device attached to the corresponding port.

## Back Panel

The power and console ports are located on the back panel of the switch.

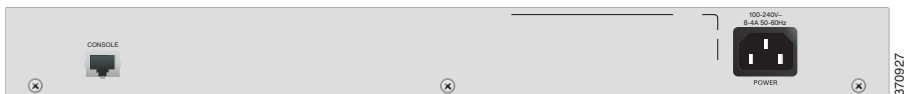

**POWER**—The power port connects the switch to power.

**CONSOLE**—The console port connects the supplied console cable to a computer's serial port for configuration using a terminal emulation program.

# 3

## Mounting the Cisco 220 Switch

There are three ways to physically install the switch:

- Place the switch on a flat surface. To place the switch on a desktop, install the four rubber feet (included) on the bottom of the switch.
- Mount the switch in a standard rack (1 rack unit high).
- Mount the switch to a wall (non-PoE models only).

### Placement Tips

- **Ambient Temperature**—To prevent the switch from overheating, do not operate it in an area that exceeds an ambient temperature of 122°F (50°C).
- **Air Flow**—Be sure that there is adequate air flow around the switch.
- **Mechanical Loading**—Be sure that the switch is level and stable to avoid any hazardous conditions.
- **Circuit Overloading**—Adding the switch to the power outlet must not overload that circuit.

### Rack Mounting

You can mount the switch in any standard size, 19-inch (about 48 cm) wide rack. The switch requires 1 rack unit (RU) of space, which is 1.75 inches (44.45 mm) high.



#### CAUTION

For stability, load the rack from the bottom to the top, with the heaviest devices on the bottom. A top-heavy rack is likely to be unstable and might tip over.

To install the switch into a 19-inch standard chassis:

- STEP 1** Attach one of the supplied brackets on the side of the switch so that the four holes align to the screw holes, and use the four supplied M5 (non-PoE models) or M4 (PoE models) screws to secure it.

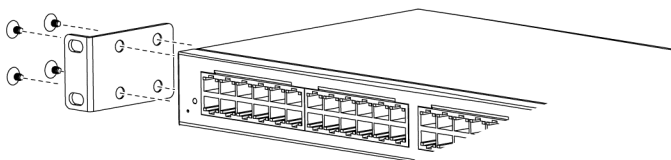

3910235

**STEP 2** Repeat the previous step to attach the other bracket to the opposite side of the switch.

**STEP 3** After the brackets are securely attached, the switch is now ready to be installed into a standard 19-inch rack as shown here.

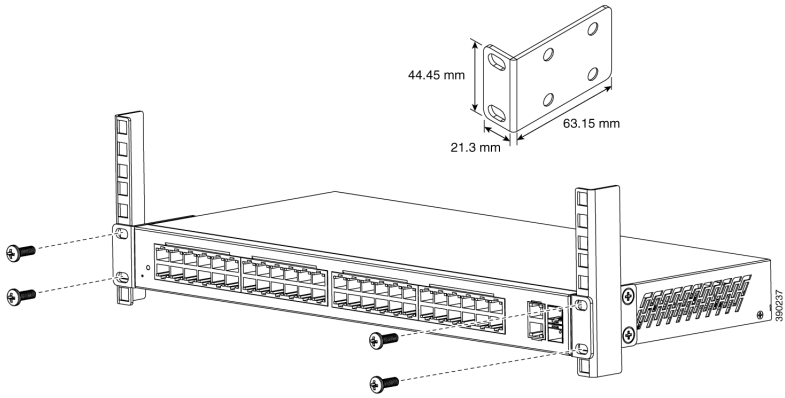

## Wall Mounting (Non-PoE Models Only)

If your switch is the non-PoE model, you can wall-mount it by utilizing the supplied rack-mount brackets. The pan head screws used to attach the brackets to the switch and the flat head screws used to attach the switch to wall are user-supplied. Suggested hardware is illustrated here.

4 Pan Head M5 Screws

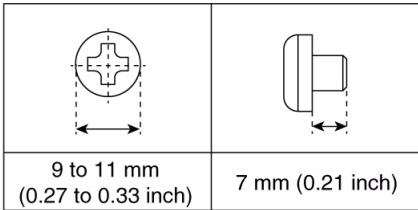

8 Flat Head M5 Screws

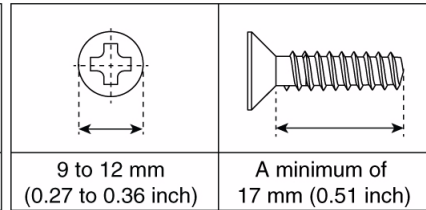

390530



### WARNING

Insecure mounting might damage the device or cause injury. Cisco is not responsible for damages incurred by insecure wall-mounting.

To mount the non-PoE switch to the wall:

- STEP 1** Determine where you want to mount the switch. Verify that the surface is smooth, flat, dry, and sturdy.
- STEP 2** Attach one of the supplied brackets to one side of the switch and use two pan head M5 screws to secure it.

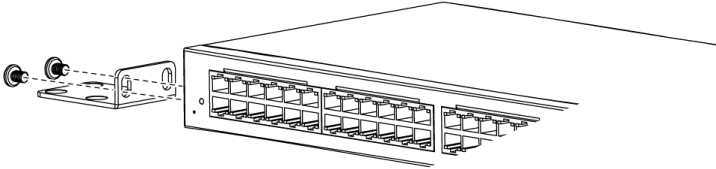

- STEP 3** Repeat the previous step to attach the other bracket to the opposite side of the switch.
- STEP 4** For the best support of the switch and cables, make sure that the switch is attached securely to wall studs or to a firmly attached plywood mounting backboard. Mount the switch with the front panel facing down as shown here.

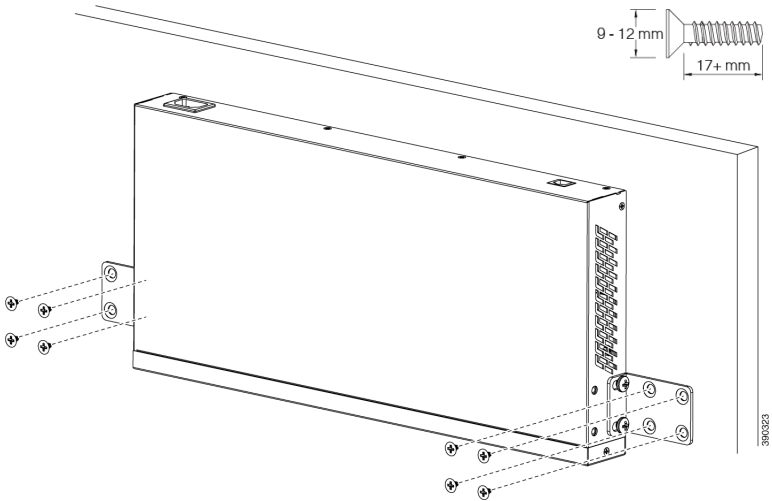

# 4

## Connecting Network Devices

To connect your switch to the network:

- 
- STEP 1** Connect an Ethernet cable to the Ethernet port of a computer, printer, network storage, or other network devices.
  - STEP 2** Connect the other end of the Ethernet cable to one of the numbered Ethernet ports of the switch. The LED of the port lights if the device connected is active.
  - STEP 3** Repeat **Step 1** and **Step 2** for each device that you want to connect to the switch.

**NOTE** We strongly recommend using CAT-5E or better cable to connect network devices. When you connect your network devices, do not exceed the maximum cabling distance of 100 meters (328 feet). It can take up to one minute for attached devices or the LAN to be operational after it is connected. This is normal behavior.

---

### Power over Ethernet (PoE) Considerations

If your switch is the PoE model, consider the following:

As a Power Sourcing Equipment (PSE) device, the switch can deliver a maximum of 30 Watts per PoE port on port 1 to 4 and 15.4 Watts per PoE port on other ports to a Powered Device (PD).

Model	Power Dedicated to PoE	PoE Ports	PoE Standard Supported
SF220-24P and SG220-26P	180 Watts	1 to 24	802.3at and 802.3af on port 1 to 4; 802.3af on port 5 to 24
SF220-48P and SG220-50P	375 Watts	1 to 48	802.3at and 802.3af on port 1 to 4; 802.3af on port 5 to 48



**WARNING**

The PoE switch should be connected only to PoE networks without routing to the outside plant.

---

**CAUTION**

---

Consider the following when connecting switches capable of supplying PoE:

The PoE models of the switches are PSEs that are capable of supplying DC power to attaching PDs. These devices include VoIP phones, IP cameras, and wireless access points. The PoE switches can detect and supply power to pre-standard legacy PoE Power Devices. Due to the support of legacy PoE, it is possible that a PoE switch acting as a PSE may mistakenly detect and supply power to an attaching PSE, including other PoE switches, as a legacy PD.

Even though PoE switches are PSEs, and as such should be powered by AC, they could be powered up as a legacy PD by another PSE due to false detection. When this happens, the PoE switch may not operate properly and may not be able to properly supply power to its attaching PDs.

To prevent false detection, you should disable PoE on the ports on the PoE switches that are used to connect to PSEs. You should also first power up a PSE device before connecting it to a PoE switch. When a device is being falsely detected as a PD, you should disconnect the device from the PoE port and power recycle the device with AC power before reconnecting its PoE ports.

---

**5**

## Configuring the Cisco 220 Switch

The Cisco 220 switch can be accessed and managed by two different methods: over your IP network by using the web-based interface, or by using the switch's command-line interface through the console port. Using the console port requires advanced skills.

These are the default settings used when configuring your switch for the first time.

Parameter	Default Value
Username	<b>cisco</b>
Password	<b>cisco</b>
LAN IP	<b>192.168.1.254</b>

## Configuring Your Switch Using the Web-based Interface

To access the switch with a web-based interface, you must know the IP address that the switch is using. The default configuration of the switch is to use its factory default IP address of **192.168.1.254** until it has obtained an IP address from a DHCP server.

**NOTE** If you are managing the switch through a network connection and the switch IP address is changed, either by a DHCP server or manually, your access to the switch will be lost. You must enter the new IP address that the switch is using into your browser to use the web-based interface. If you are managing the switch through a console port connection, the link is retained.

To configure the switch using the web-based interface:

---

**STEP 1** Power on the computer and your switch.

**STEP 2** Connect the computer to the switch.

You can connect to the same IP subnet as the switch by connecting them directly with an Ethernet cable, or by connecting to the same LAN where the switch is located through other switches. You can also connect your computer to the switch from another IP subnet through one or more IP routers.

**STEP 3** Locate the IP address of the switch.

- a. The switch can be accessed and managed by Cisco network tools and services including the Cisco FindIT Network Discovery Utility that enables you to automatically discover all supported Cisco devices in the same local network segment as your computer. You can get a snapshot view of each device or launch the product configuration utility to view and configure the settings. For more information, see [www.cisco.com/go/findit](http://www.cisco.com/go/findit).
- b. Locate the IP address assigned by your DHCP server by accessing your router or DHCP server; see your DHCP server instructions for information. Make sure that your DHCP server is running and can be reached.

**STEP 4** Set up the IP configuration on your computer.

- a. If the switch is using the default static IP address of 192.168.1.254, you must choose an IP address in the range of 192.168.1.2 to 192.168.1.253 that is not already in use.
- b. If the IP addresses will be assigned by DHCP, make sure that your DHCP server is running and can be reached from the switch and the computer. You may need to disconnect and

reconnect the devices for them to discover their new IP addresses from the DHCP server.

**NOTE** Details on how to change the IP address on your computer depend upon the type of architecture and operating system that you are using. Use your computers local Help and Support functionality and search for “IP Addressing.”

- STEP 5** Open a web browser window. If you are prompted to install an Active-X plug-in when connecting to the device, follow the prompts to accept the plug-in.
- STEP 6** Enter the switch IP address in the address bar and press **Enter**. For example, **http://192.168.1.254**.
- STEP 7** When the login page appears, choose the language that you prefer to use in the web-based interface and enter the username and password.

The default username is **cisco**. The default password is **cisco**. Usernames and passwords are both case sensitive.

- STEP 8** Click **Log In**.

If this is the first time that you have logged on with the default username and password, the Change Password page opens.

- STEP 9** Enter a new password and confirm the password.

**NOTE** Password complexity is enabled by default. The password must comply with the default complexity rules or it can be disabled temporarily by selecting **Disable Password Strength Enforcement**.

- STEP 10** Click **Apply**.



**CAUTION**

---

Make sure that any configuration changes made are saved before exiting from the web-based interface by clicking on the **Save** icon. Exiting before you save your configuration will result in all changes being lost.

---

The Getting Started page opens. You are now ready to configure the switch. Refer to the *Cisco 220 Series Smart Plus Switches Administration Guide* or see the help pages for further information.

---

## Configuring Your Switch Using the Console Port

To configure the switch using the console port:

- 
- STEP 1** Connect a computer to the switch console port using the supplied console cable.
- STEP 2** Start a console port utility such as HyperTerminal on the computer.
- STEP 3** Configure the utility with the following parameters:
- 9,600 bits per second
  - 8 data bits
  - no parity
  - 1 stop bit
  - no flow control
- STEP 4** Enter a username and password. The default username is **cisco**, and the default password is **cisco**. Usernames and passwords are both case sensitive.

If this is the first time that you have logged on with the default username and password, the following message appears:

```
Please change your password from the default
settings. Please change the password for better
protection of your network. Do you want to change
the password (Y/N) [Y]?
```

- STEP 5** Enter **Y**, and set a new administrator password.

**NOTE** Password complexity is enabled by default. The password must comply with the default complexity rules.



**CAUTION**

---

Make sure that any configuration changes made are saved before exiting.

---

You are now ready to configure the switch. Refer to the *Cisco 220 Series Smart Plus Switches Command Line Interface Reference Guide* for further information.

---

## Troubleshoot Your Connection

If you cannot access your switch from the web-based interface, the switch may not be reachable from your computer. You can test network connections by using ping on a computer running Windows:

---

**STEP 1** Open a command window by selecting **Start > Run** and enter **cmd**.

**STEP 2** At the **Command** window prompt, enter **ping** and the switch IP address. For example, **ping 192.168.1.254** (the default static IP address of the switch).

If you can reach the switch, you should get a reply similar to the following:

```
Pinging 192.168.1.254 with 32 bytes of data:  
Reply from 192.168.1.254:bytes=32 time<1ms TTL=128
```

If you cannot reach the switch, you should get a reply similar to the following:

```
Pinging 192.168.1.254 with 32 bytes of data:  
Request timed out.
```

---

## Possible Causes and Resolutions

### *No Power:*

Power up the switch and your computer if they are turned off.

### *Bad Ethernet connection:*

Check the LEDs for proper indications. Check the connectors of the Ethernet cable to ensure that they are firmly plugged into the switch and your computer.

### *Bad Console port connection:*

Check the console cable connectors to make sure that they are firmly plugged into the switch and your computer. Make sure that the console port utility is configured with the correct parameters.

### *Wrong IP address:*

Make sure that you are using the correct IP address of the switch. You can determine the current IP address of the switch from the CLI through the console port, or from your network administrator. The System LED provides an indication of where the switch received the IP address (See [Front Panel, page 3](#) for details.) Make sure that no other device is using the same IP address as the switch.

### *No IP route:*

If the switch and your computer are in different IP subnets, you need one or more routers to route the packets between the two subnets.

### *Unusually long access time:*

Due to the standard spanning tree loop detection logic, adding new connections may take 30 to 60 seconds for the affected interfaces and/or LAN to become operational.

## 6

## Returning the Cisco 220 Switch to the Factory Default Settings

- To **reboot** the switch, press and hold the **Reset** button for less than ten seconds.
- To **restore** the switch to its factory default settings:
  - Disconnect the switch from the network or disable all DHCP servers on your network.
  - With the power on, press and hold the **Reset** button for more than ten seconds.

## 7

## Where to Go From Here

Support	
Cisco Support Community	<a href="http://www.cisco.com/go/smallbizsupport">www.cisco.com/go/smallbizsupport</a>
Cisco Support and Resources	<a href="http://www.cisco.com/go/smallbizhelp">www.cisco.com/go/smallbizhelp</a>
Phone Support Contacts	<a href="http://www.cisco.com/en/US/support/tsd_cisco_small_business_support_center_contacts.html">www.cisco.com/en/US/support/tsd_cisco_small_business_support_center_contacts.html</a>
Cisco Firmware Downloads	<a href="http://www.cisco.com/go/smallbizfirmware">www.cisco.com/go/smallbizfirmware</a> Select a link to download firmware for Cisco Products. No login is required.
Cisco Open Source Requests	<a href="http://www.cisco.com/go/smallbiz_opensource_request">www.cisco.com/go/smallbiz_opensource_request</a>
Product Documentation	
Cisco 220 Series Switches	<a href="http://www.cisco.com/go/220switches">www.cisco.com/go/220switches</a>
Regulatory Compliance and Safety Information	<a href="http://www.cisco.com/en/US/docs/switches/lan/csb_switching_general/rcsi/Switch_ClassA_RCSI.pdf">www.cisco.com/en/US/docs/switches/lan/csb_switching_general/rcsi/Switch_ClassA_RCSI.pdf</a>
Warranty Information	<a href="http://www.cisco.com/go/warranty">www.cisco.com/go/warranty</a>
Other Cisco Sources	
Cisco Partner Central (Partner Login Required)	<a href="http://www.cisco.com/web/partners/sell/smb">www.cisco.com/web/partners/sell/smb</a>

**WARNING**

This is a class A product. In a domestic environment this product may cause radio interference in which case the user may be required to take adequate measures.

## Americas Headquarters

Cisco Systems, Inc.  
170 West Tasman Drive  
San Jose, CA 95134-1706  
USA

[www.cisco.com](http://www.cisco.com)

Small Business Support, Global: [www.cisco.com/go/sbsc](http://www.cisco.com/go/sbsc)



**78-21267-01**

Cisco and the Cisco logo are trademarks or registered trademarks of Cisco and/or its affiliates in the U.S. and other countries. To view a list of Cisco trademarks, go to this URL: [www.cisco.com/go/trademarks](http://www.cisco.com/go/trademarks). Third-party trademarks mentioned are the property of their respective owners. The use of the word partner does not imply a partnership relationship between Cisco and any other company. (1110R)

© 2014 Cisco Systems, Inc. All rights reserved.